

Common Mode Choke Coils(Line Filters) for AC Power Supply

Closed Magnetic Circuit Core Type HF Series

Conformity to RoHS Directive

TDK common mode choke coils(line filters) are used in a wide range of prevention of electromagnetic interference(EMI) and radio frequency interference(RFI) from power supply lines and for prevention of multifunctioning of products such as measuring equipment and system equipment.

FEATURES

- Wide range of selection.
- High impedance at applicable frequency.
- High self-resonant frequency.

PRODUCT IDENTIFICATION

HF □□□□ V - A □□□Y □R□ - 01
 (1) (2) (3) (4) (5) (6) (7)

- (1) Core shape
HF: Square shaped closed magnetic circuit core type
- (2) Dimensional code
Width×Depth
- (3) External shape code
V: Vertical type H: Horizontal type
- (4) High μ material
- (5) Inductance value
Example) 133:13mH
- (6) Rated current value
Example) 3R0:3.0A
- (7) Product management number

SELECTION CHART

Series	Configuration	Type	Inductance value min.	Rated current (A)	Handling power* $L \times I^2$ (mH×A ²)	Weight (g)typ.	Minimum package quantity (pieces/box)
HF	Vertical type	HF2316	1.2 to 145mH	0.2 to 3	10.5	10.5	800
		HF2318	1.5 to 100mH	0.3 to 3	13	13.5	800
		HF2922	3.2 to 100mH	0.5 to 3	29	20	440

* Handling power=(Inductance value)×(Current)². It is possible to design within the range below this value.
 [Example] The coil for 2A can make even the inductance of 2.5mH or less a product for handling power 10.

• Conformity to RoHS Directive: This means that, in conformity with EU Directive 2002/95/EC, lead, cadmium, mercury, hexavalent chromium, and specific bromine-based flame retardants, PBB and PBDE, have not been used, except for exempted applications.

• All specifications are subject to change without notice.

Closed Magnetic Circuit Core Type HF Series

FEATURES

- As closed magnetic circuit core as same as a toroidal core, even at its compact size, it offers large inductance and keeps the high impedance levels required in high frequency ranges.
- Since it uses a closed magnetic circuit core, the leakage flux is relatively small, allowing designers to improve the mounting density of their circuits.

HF2316-A(SQUARE SHAPED CLOSED MAGNETIC CIRCUIT CORE) TYPE

SHAPES AND DIMENSIONS/CIRCUIT DIAGRAM

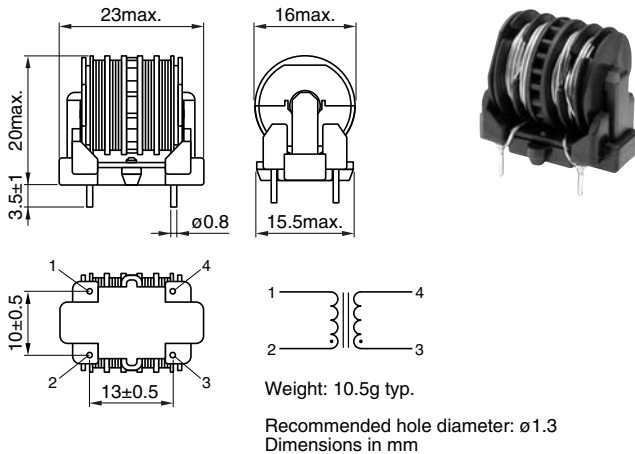

TYPICAL ELECTRICAL CHARACTERISTICS IMPEDANCE vs. FREQUENCY CHARACTERISTICS

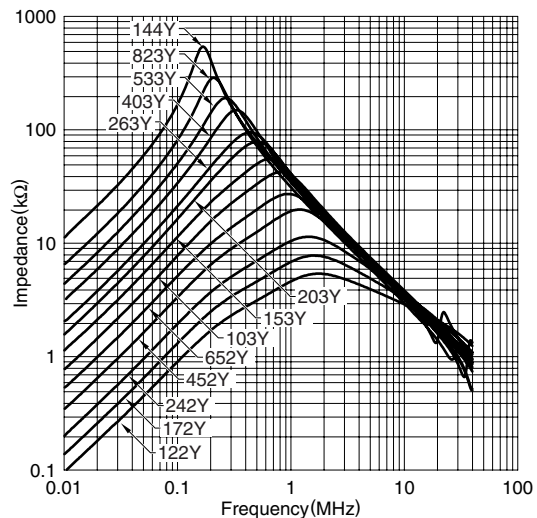

ELECTRICAL CHARACTERISTICS (STANDARD LINE UP)

Part No.	Inductance (mH)min.	DC resistance (Ω)max.	Rated current Iac(A)max.
HF2316-A144Y0R2-01	145	6.8	0.2
HF2316-A823Y0R3-01	82	4	0.3
HF2316-A533Y0R4-01	53	2.4	0.4
HF2316-A403Y0R5-01	40	1.7	0.5
HF2316-A263Y0R6-01	26	1.2	0.6
HF2316-A203Y0R7-01	20	1	0.7
HF2316-A153Y0R8-01	15	0.7	0.8
HF2316-A103Y1R0-01	10	0.5	1
HF2316-A652Y1R2-01	6.5	0.3	1.2
HF2316-A452Y1R5-01	4.5	0.2	1.5
HF2316-A242Y2R0-01	2.4	0.12	2
HF2316-A172Y2R5-01	1.7	0.09	2.5
HF2316-A122Y3R0-01	1.2	0.06	3

- Measuring equipment of inductance value:
LCR meter(HP4261A, HP4263B or equivalent)[f=1kHz]

PACKAGING QUANTITIES

HF2316-A	800pieces/box
----------	---------------

RATINGS

Item	Standard value	Conditions
Rated voltage(V)	80 to 280	50Hz/60Hz
Dielectric withstanding voltage(V)	2000	Between each winding for 1 minute
Insulation resistance (MΩ)	100min.	Between each winding for DC.500V
Temperature rise(°C)	45max.	With line resistance
Operating temperature range(°C)	-20 to +120	Including self-temperature rise
Storage temperature range(°C)	-20 to +85	
Resistance to soldering temperature*1	260±5°C, 10±1sec	Solder bath method
	350±5°C, 5sec max.	Soldering iron method
Applicable safety standard*2	Electrical Appliance and Material Safety Law ("DENAN"), IEC60065, UL6500, CSA C22.2	

*1 Pb free solder(Sn-3Ag-0.5Cu)

*2 However, this product is not recognized by each regulations.

HF2318-A(SQUARE SHAPED CLOSED MAGNETIC CORE) TYPE SHAPES AND DIMENSIONS/CIRCUIT DIAGRAM

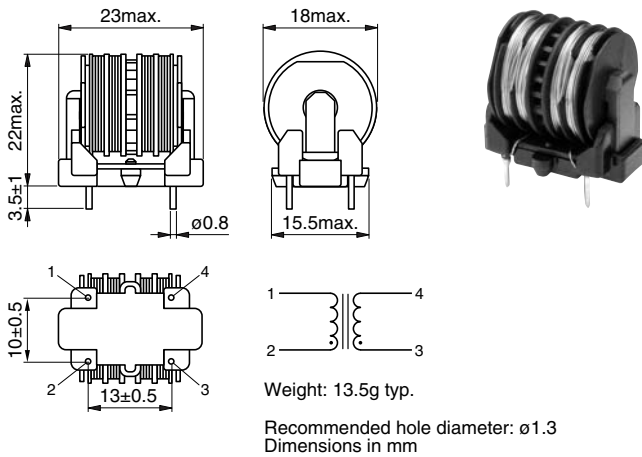

TYPICAL ELECTRICAL CHARACTERISTICS IMPEDANCE vs. FREQUENCY CHARACTERISTICS

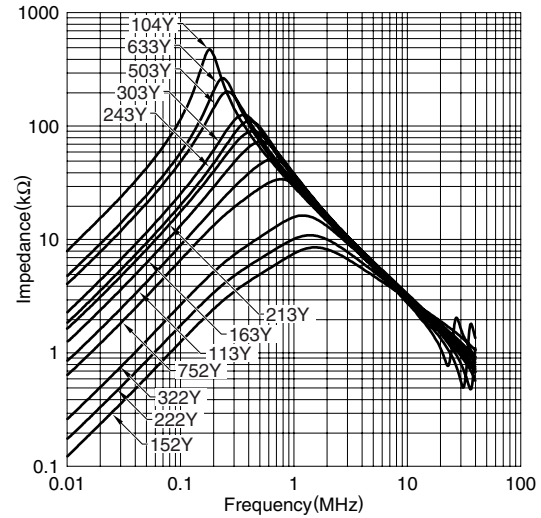

ELECTRICAL CHARACTERISTICS (STANDARD LINE UP)

Part No.	Inductance (mH)min.	DC resistance (Ω)max.	Rated current Iac(A)max.
HF2318-A104Y0R3-01	100	3.6	0.3
HF2318-A633Y0R4-01	63	2.2	0.4
HF2318-A503Y0R5-01	50	1.8	0.5
HF2318-A303Y0R6-01	30	1.1	0.6
HF2318-A243Y0R7-01	24	1	0.7
HF2318-A213Y0R8-01	21	0.75	0.8
HF2318-A163Y1R0-01	16	0.5	1
HF2318-A113Y1R2-01	11	0.35	1.2
HF2318-A752Y1R5-01	7.5	0.26	1.5
HF2318-A322Y2R0-01	3.2	0.12	2
HF2318-A222Y2R5-01	2.2	0.1	2.5
HF2318-A152Y3R0-01	1.5	0.07	3

- Measuring equipment of inductance value:
LCR meter(HP4261A, HP4263B or equivalent)[f=1kHz]

PACKAGING QUANTITIES

HF2316-A	800pieces/box
----------	---------------

RATINGS

Item	Standard value	Conditions
Rated voltage(V)	80 to 280	50Hz/60Hz
Dielectric withstanding voltage(V)	2000	Between each winding for 1 minute
Insulation resistance (MΩ)	100min.	Between each winding for DC.500V
Temperature rise(°C)	45max.	With line resistance
Operating temperature range(°C)	-20 to +120	Including self-temperature rise
Storage temperature range(°C)	-20 to +85	
Resistance to soldering temperature*1	260±5°C, 10±1sec	Solder bath method
Applicable safety standard*2	350±5°C, 5sec max.	Soldering iron method
	Electrical Appliance and Material Safety Law ("DENAN"), IEC60065, UL6500, CSA C22.2	

*1 Pb free solder(Sn-3Ag-0.5Cu)

*2 However, this product is not recognized by each regulations.

HF2922-A(SQUARE SHAPED CLOSED MAGNETIC CIRCUIT CORE) TYPE SHAPES AND DIMENSIONS/CIRCUIT DIAGRAM

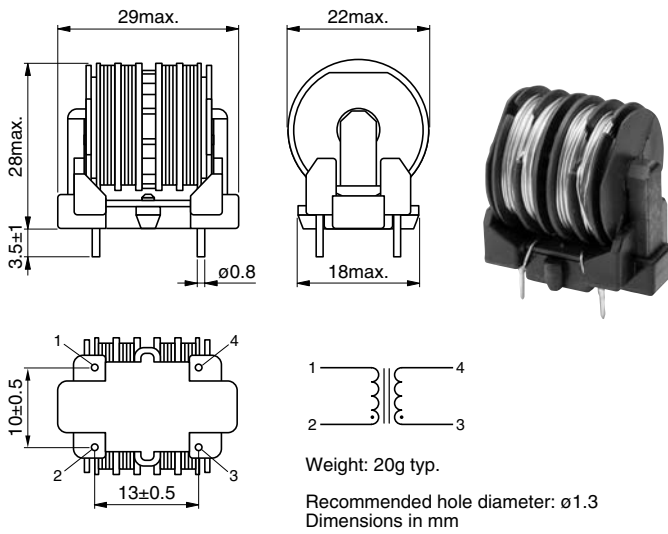

ELECTRICAL CHARACTERISTICS (STANDARD LINE UP)

Part No.	Inductance (mH)min.	DC resistance (Ω)max.	Rated current Iac(A)max.
HF2922-A104Y0R5-01	100	1.7	0.5
HF2922-A503Y0R8-01	50	0.95	0.8
HF2922-A323Y1R0-01	32	0.59	1
HF2922-A203Y1R2-01	20	0.38	1.2
HF2922-A133Y1R6-01	13	0.25	1.6
HF2922-A952Y2R0-01	9.5	0.19	2
HF2922-A502Y2R5-01	5	0.12	2.5
HF2922-A322Y3R0-01	3.2	0.08	3

- Measuring equipment of inductance value:
LCR meter(HP4261A, HP4263B or equivalent)[f=1kHz]

PACKAGING QUANTITIES

HF2316-A	440pieces/box
----------	---------------

TYPICAL ELECTRICAL CHARACTERISTICS IMPEDANCE vs. FREQUENCY CHARACTERISTICS

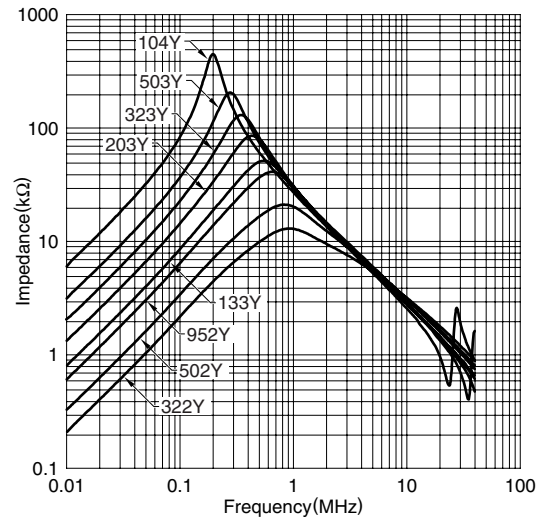

RATINGS

Item	Standard value	Conditions
Rated voltage(V)	80 to 280	50Hz/60Hz
Dielectric withstanding voltage(V)	2000	Between each winding for 1 minute
Insulation resistance (M Ω)	100min.	Between each winding for DC.500V
Temperature rise($^{\circ}$ C)	45max.	With line resistance
Operating temperature range($^{\circ}$ C)	-20 to +120	Including self-temperature rise
Storage temperature range($^{\circ}$ C)	-20 to +85	
Resistance to soldering temperature*1	260 \pm 5 $^{\circ}$ C, 10 \pm 1sec	Solder bath method
Applicable safety standard*2	350 \pm 5 $^{\circ}$ C, 5sec max.	Soldering iron method
	Electrical Appliance and Material Safety Law ("DENAN"), IEC60065, UL6500, CSA C22.2	

*1 Pb free solder(Sn-3Ag-0.5Cu)

*2 However, this product is not recognized by each regulations.